

# LUMP BREAKER KAL30

FOR THE SIZE REDUCTION OF LUMPS AND AGGLOMERATIONS

- Rotor with built up adjustable Baffle plate  
- ball bearing mounted on both sides
- Easy exchangeable screen with safety switch



Screen slide out  
mechanism allows fast  
and easy cleaning!



## Functional principle:

Rotating paddles generate centrifugal force, which presses the material through the stationary screen made of perforated sheet metal. Lumps and agglomerations larger than the screen mesh are hence reduced to the size of the screen mesh width.

The screen slide out mechanism and fast action clamps allow fast cleaning and screen exchange without the use of tools. The throughput performance depends on the specific product properties, particle size and screen mesh width.

## Design:

- Rotor with adjustable built up baffle plate – ball bearing mounted on both sides
- Bearing on both sides for air purge fitting
- Welded stainless steel housing with flange connection
- Inlet and outlet
- Screen with front plate
- Slide out design
- Fast and easy exchange of screen with fast action clamps and safety switch
- Cleaning lid can be tilt-up on one side with fast action clamps and safety switch
- 1 drive station consisting of: geared motor 4 kW, torsionally flexible coupling, engine bracket
- In stainless steel, material AISI 304
- Surface: pickled and passivated

## Option:

- Additional screen
- Air purge fitting
- Specially tailored designs for the foods-, animal feed-, chemical and plastics-industries
- Dust explosion rated design (ATEX)

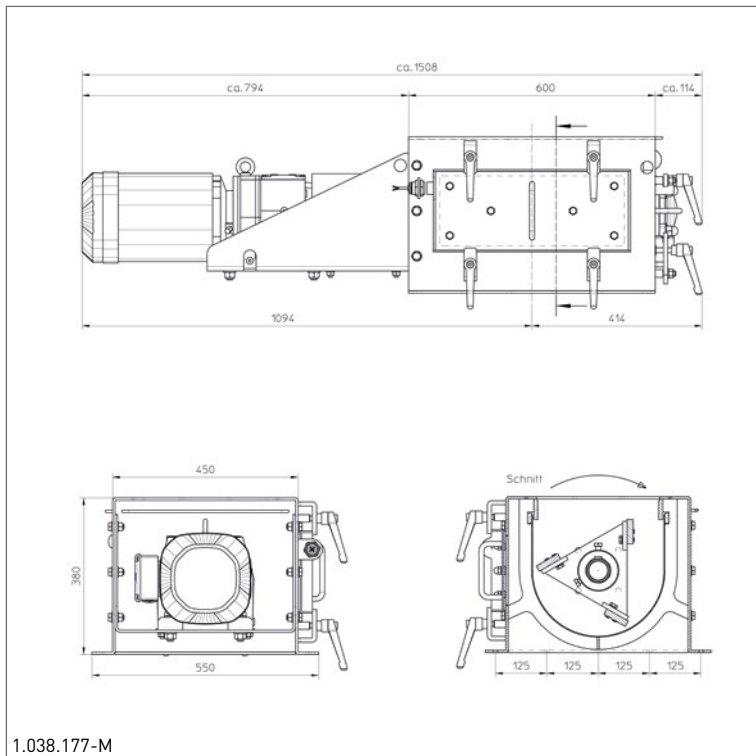

## Special advantages of lump breaker:

- Slide out mechanism
- Fast and easy screen exchange with fast action clamps and safety switch
- Sturdy design

Daxner GmbH  
Vogelweiderstrasse 41  
4600 Wels/Austria

Tel.: +43 / 7242 / 44 227-0  
Fax: +43 / 7242 / 44 227-80  
office@daxner.com

Daxner GERMANY GmbH  
97922 Lauda-Königshofen/Germany

Daxner UK  
Daxner USA  
Daxner SOUTH-EAST ASIA  
Daxner RUSSIA  
Daxner LATAM



www.daxner.com